

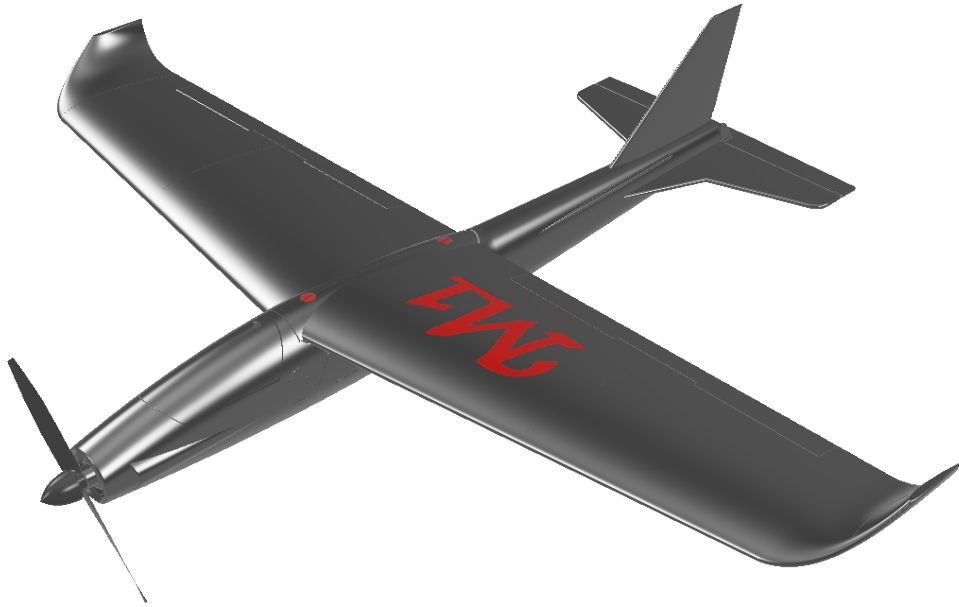

# M1

print parts



data sheet: M1	
Wingspan:	955mm (37.5 inches)
Length:	736mm (28.9 inches)
Height:	144mm (5.6 inches)
Wing loading:	57.35g/dm <sup>2</sup>
Center of gravity:	55 mm / 2.1 in = from leading edge
Airfoil:	NACA_2411
Print weight (LW PLA):	521g
Take off weight:	890g
Motor:	BL Outrunner 2826/12 1450 KV
ESC:	EP Aer33-Aer-Series 33A Flug ESC
Propeller:	APC PROPELLERS Slowfly-Propeller 8x3.8 "
Battery:	3S 11.1V 1250mAh 30C/60C
for 3-channel control	Motor, elevator, ailerons





# M1

print parts

## Fuselage 1 (PLA)

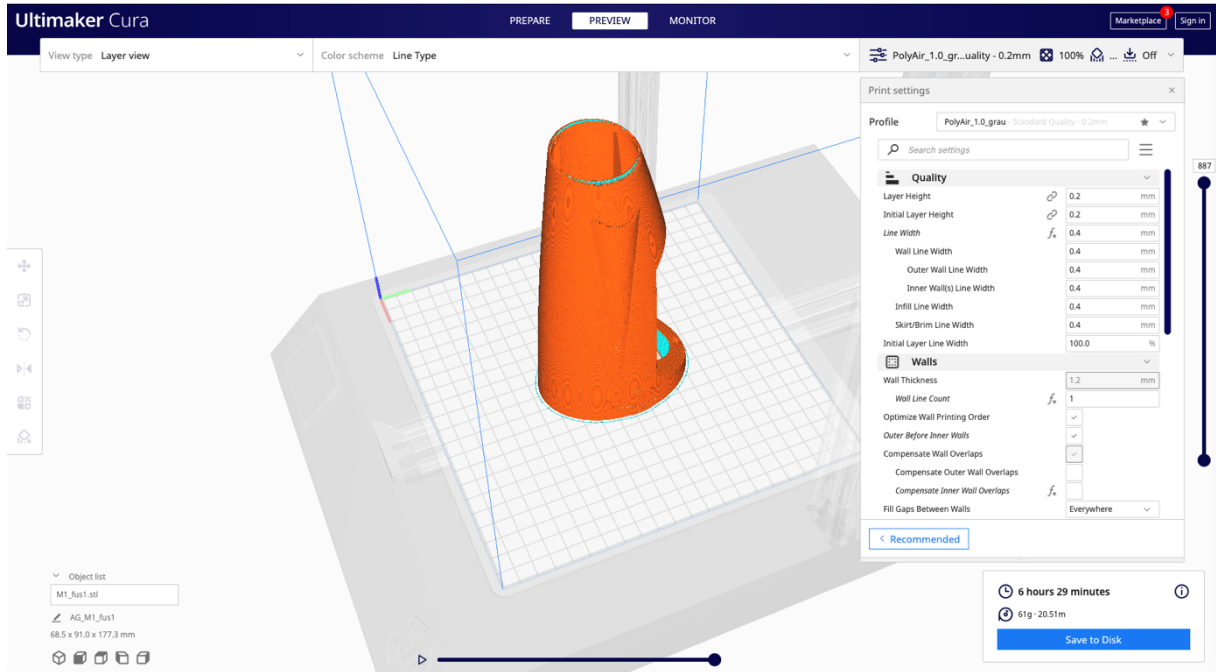

## Fuselage 2 (LW-PLA)

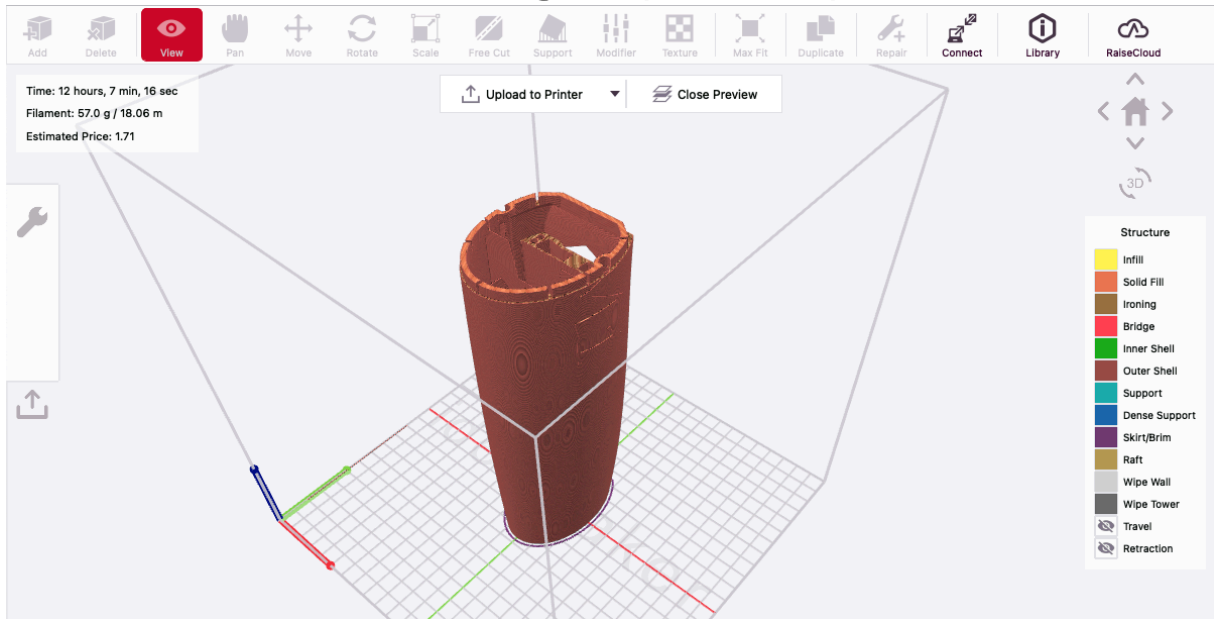



# M1

print parts

## Fuselage 3 (LW-PLA)

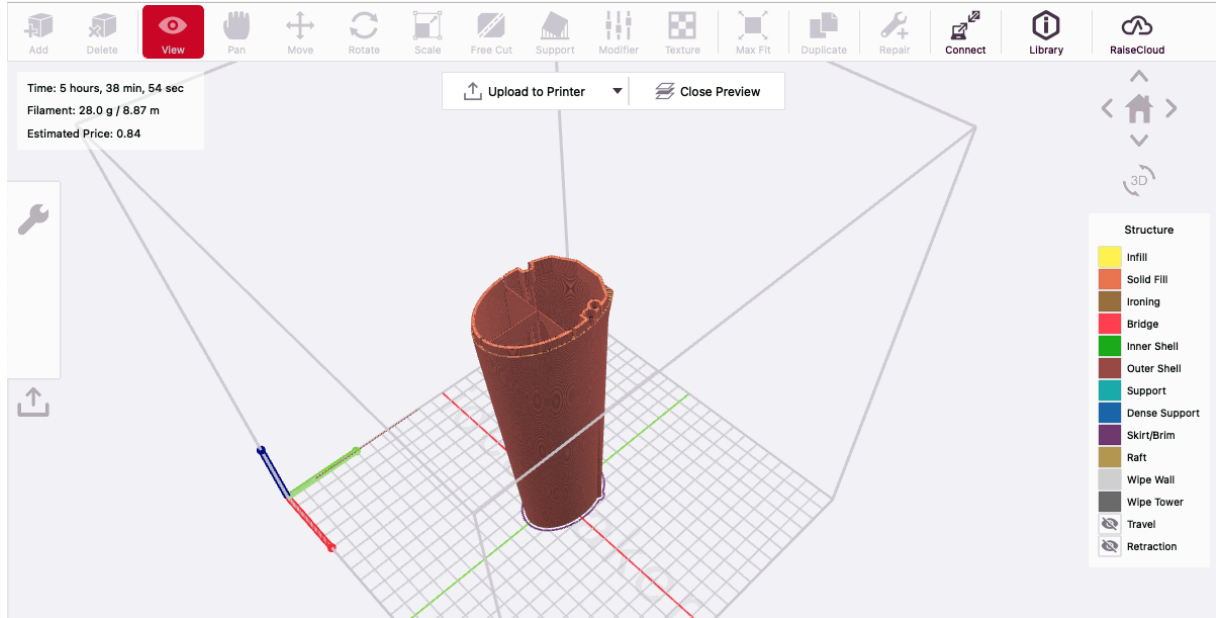

## Fuselage 4 (LW-PLA)

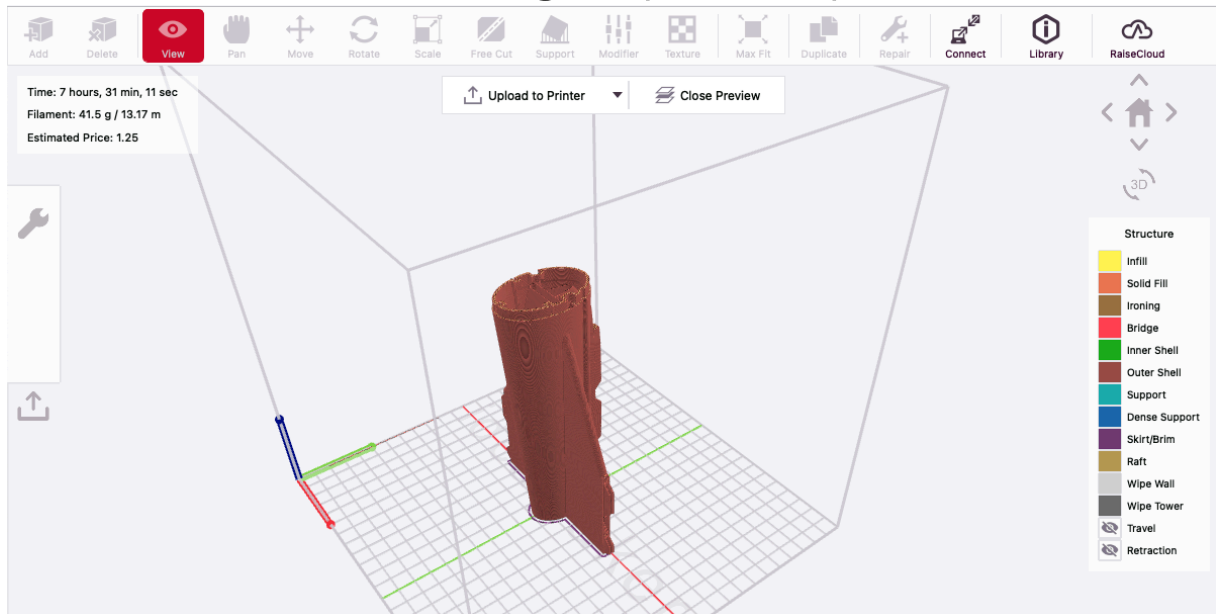



# M1

print parts

## Battery cap (PLA)

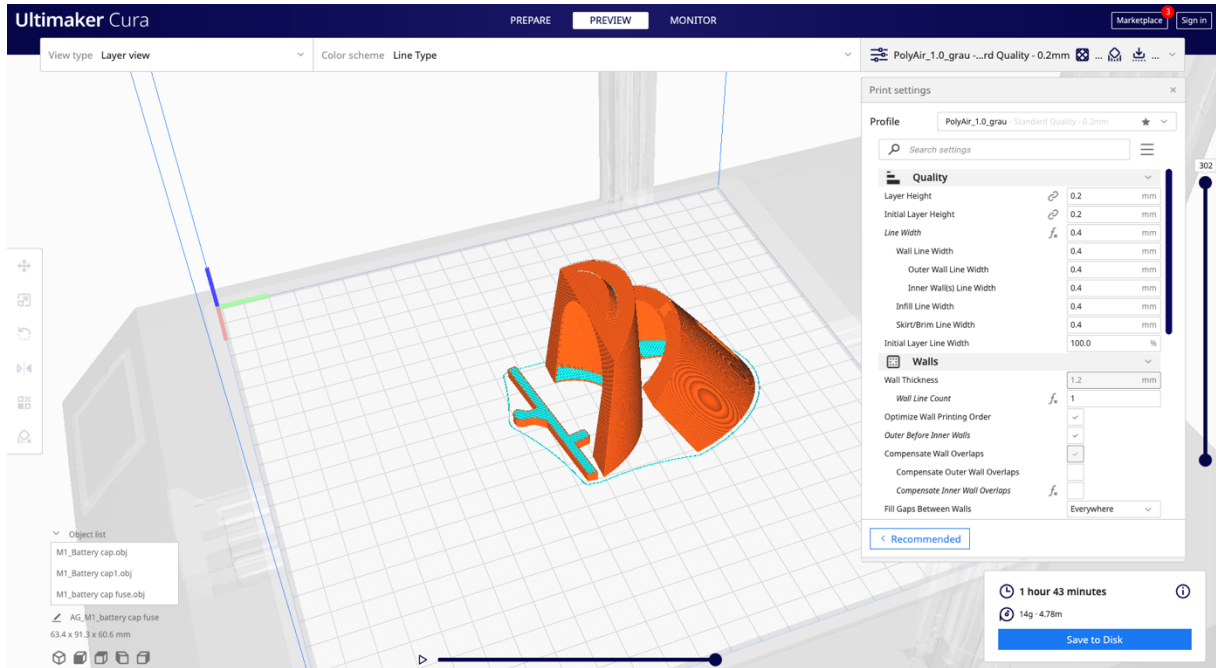

## Motor mount (PLA)

!! The correct angle to the right and down is already set. !!

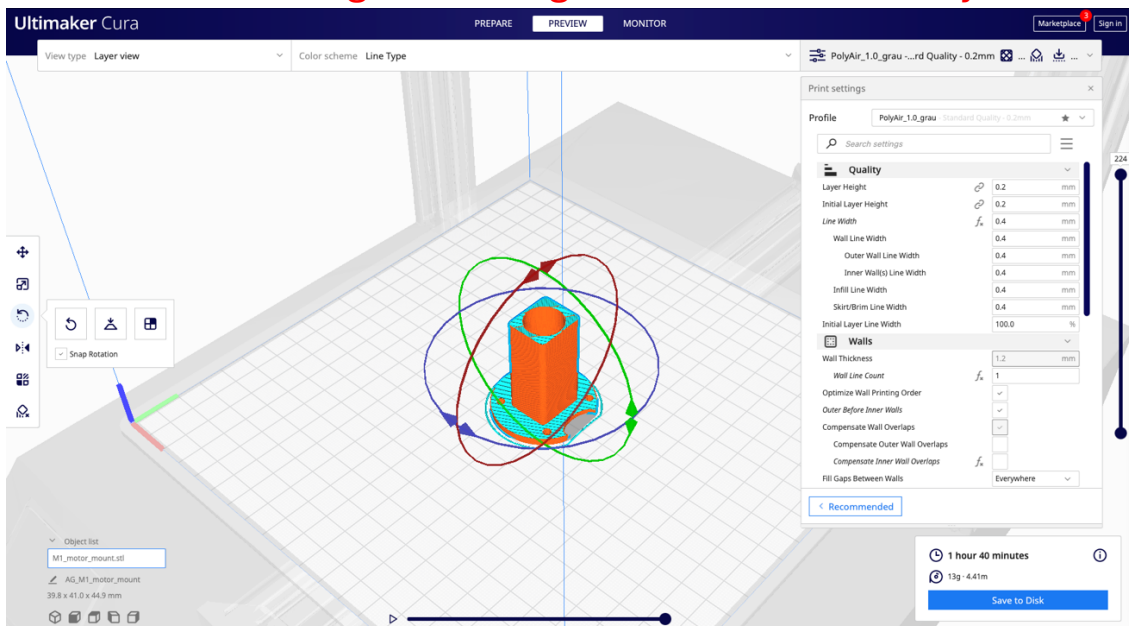



# M1

print parts

## Spinner (PLA)

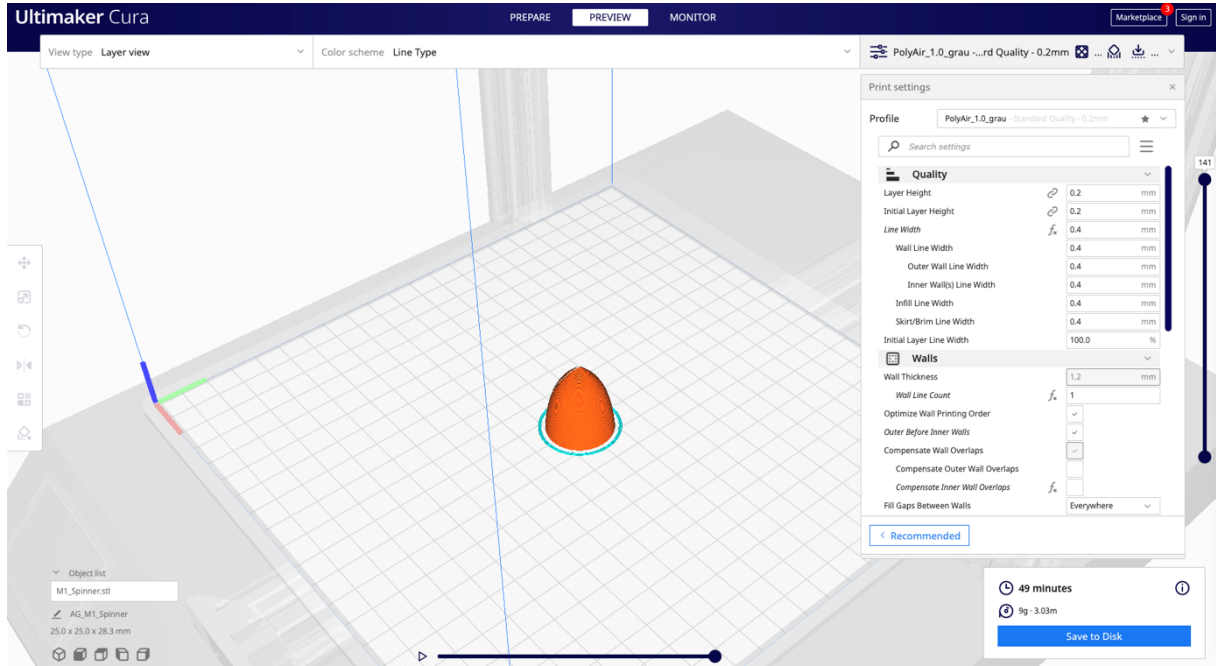

## M6\_screw (PLA)

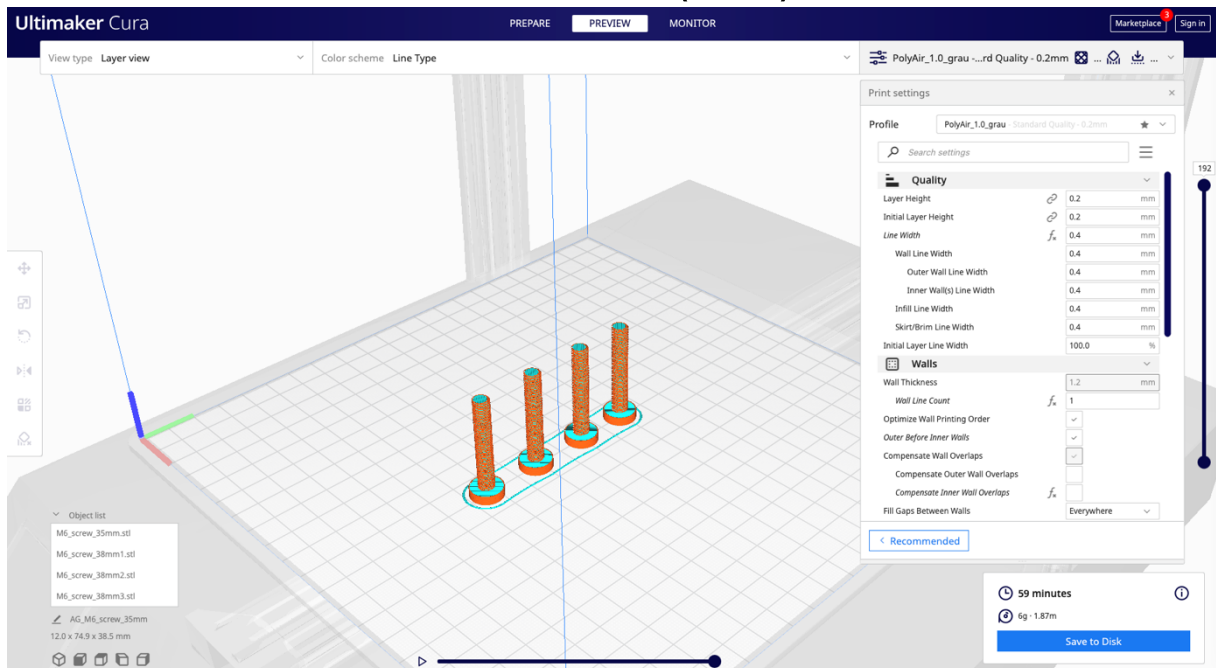



# M1

print parts

## Wing 2-3 connecting sleeve (PLA)

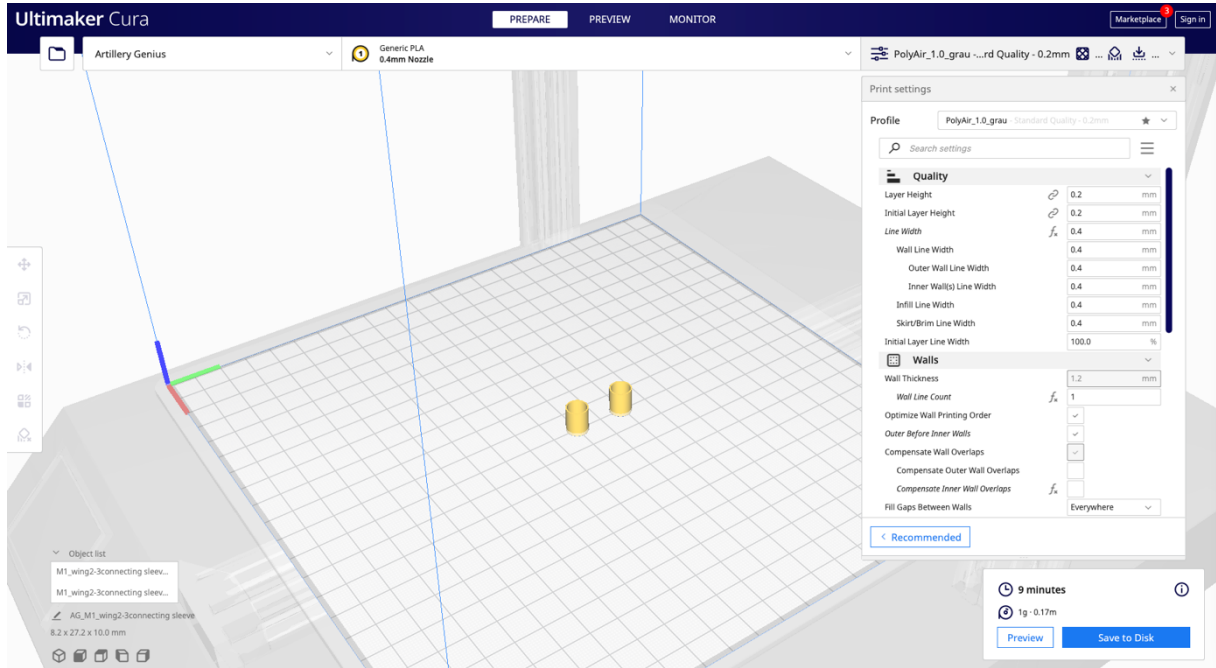

## Elevator\_hinge (PLA)

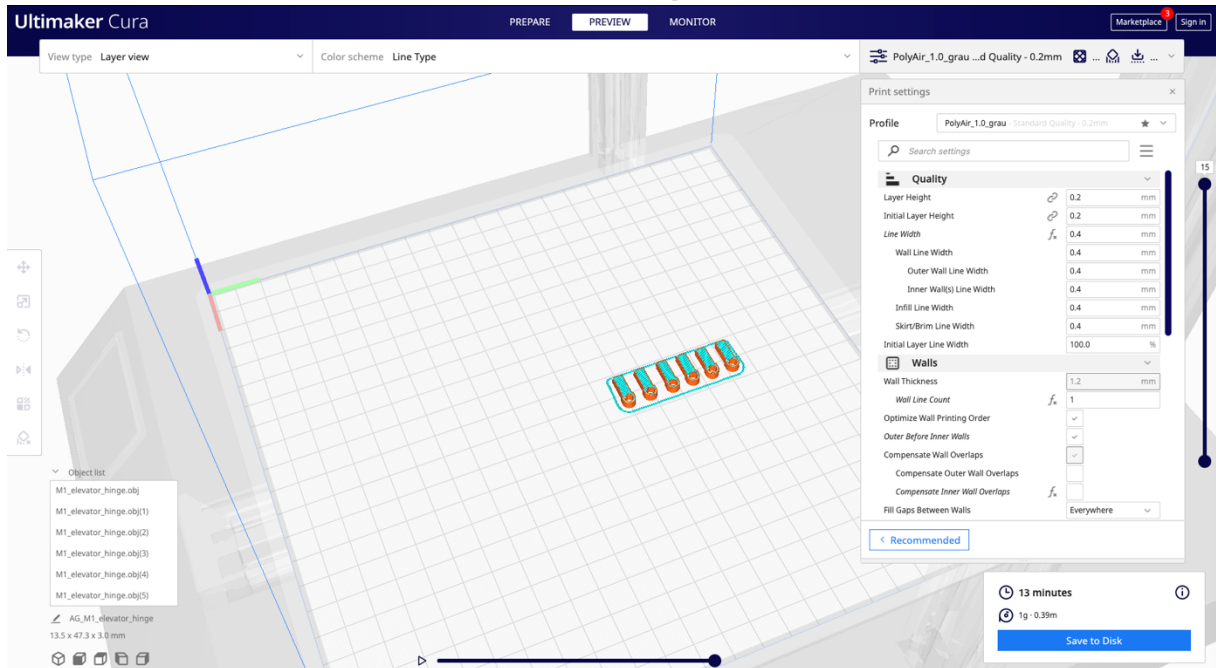



# M1

print parts

## Wing 1L (LW-PLA)

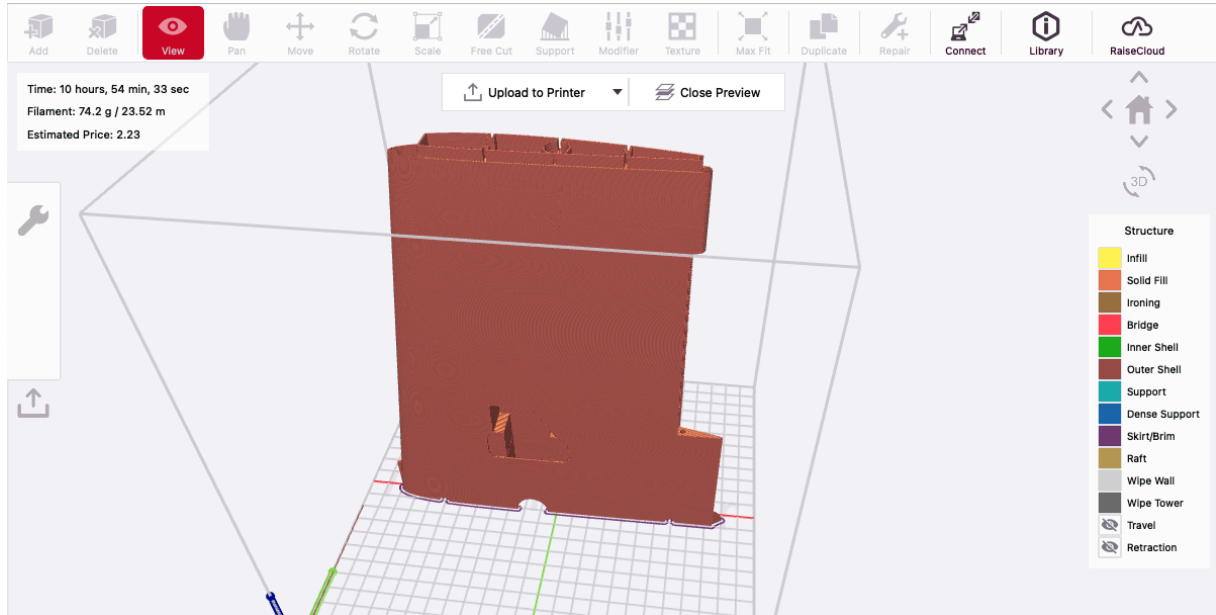

## Wing 2L (LW-PLA)

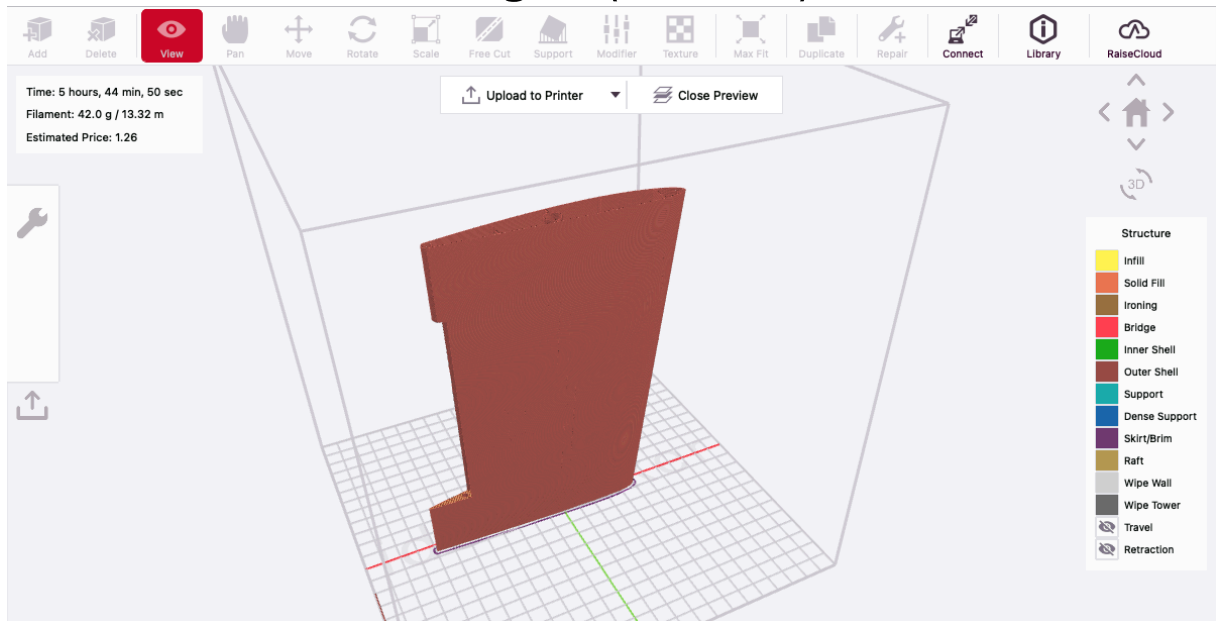



# M1

print parts

## Wing 3L (LW-PLA)

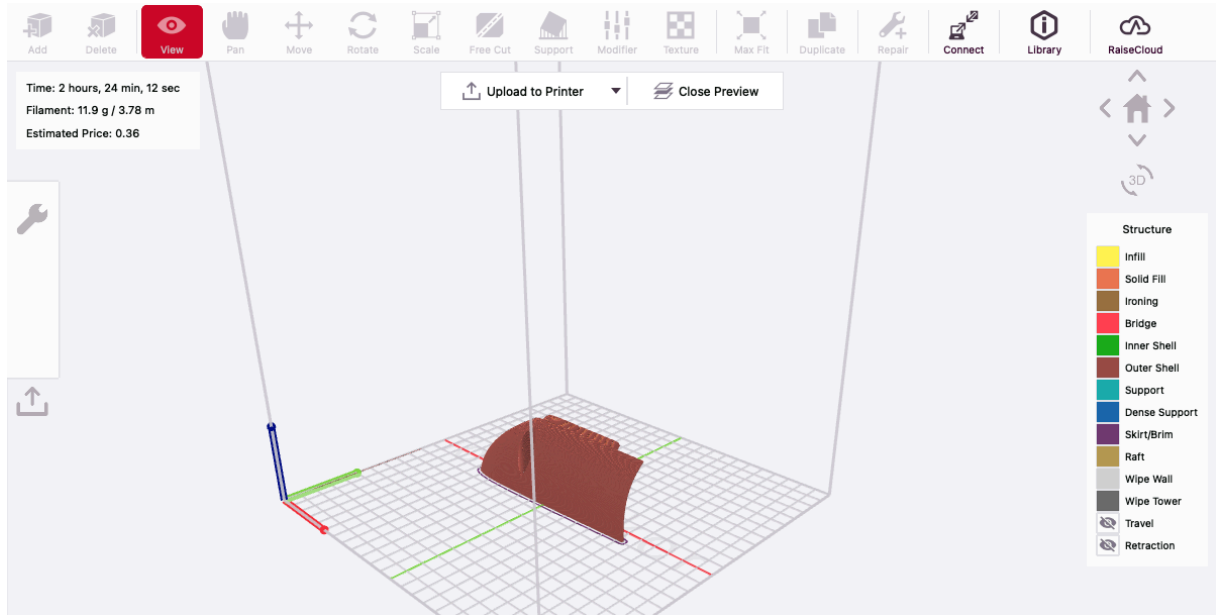

## Wing 4L (LW-PLA)

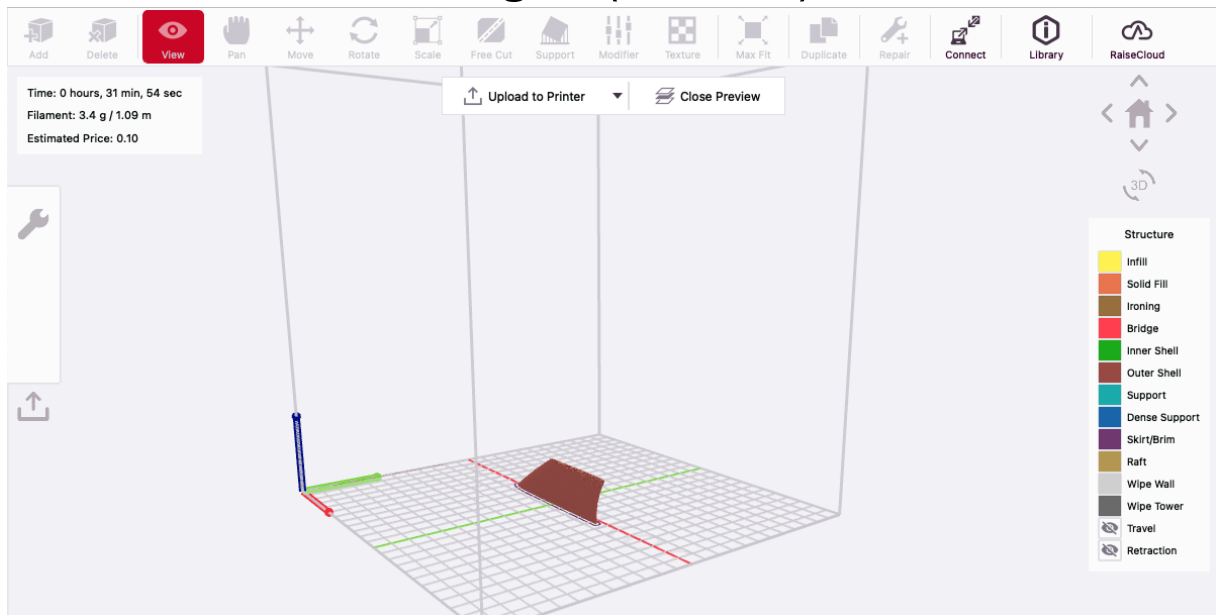





# M1

print parts

## Wing 1R (LW-PLA)

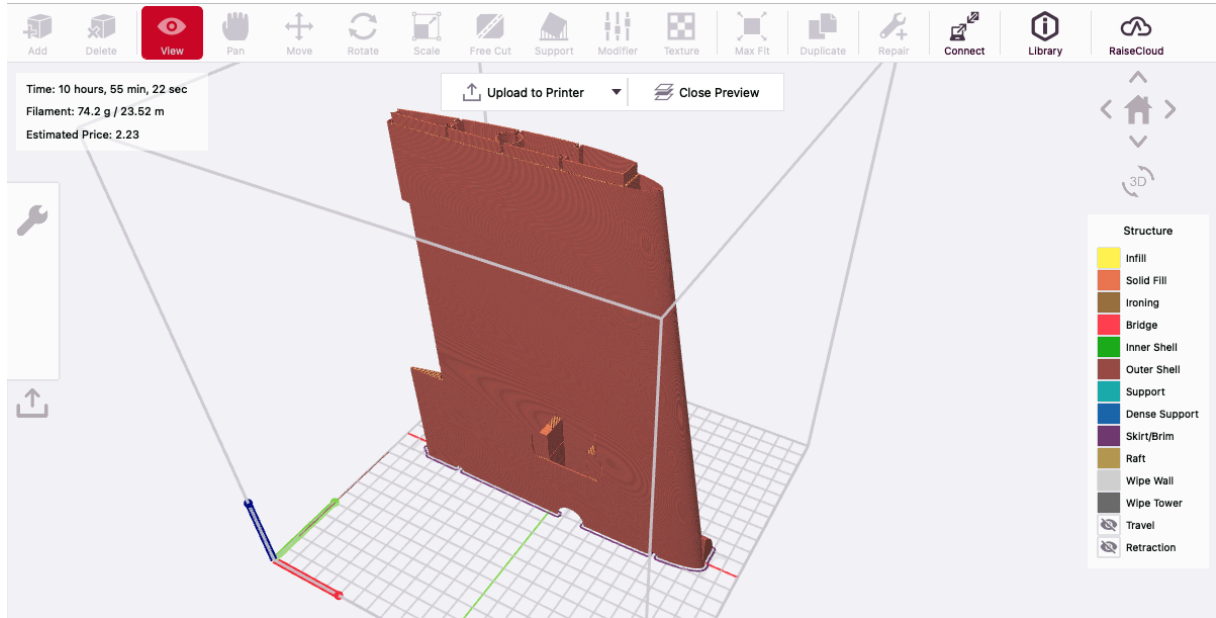

## Wing 2R (LW-PLA)

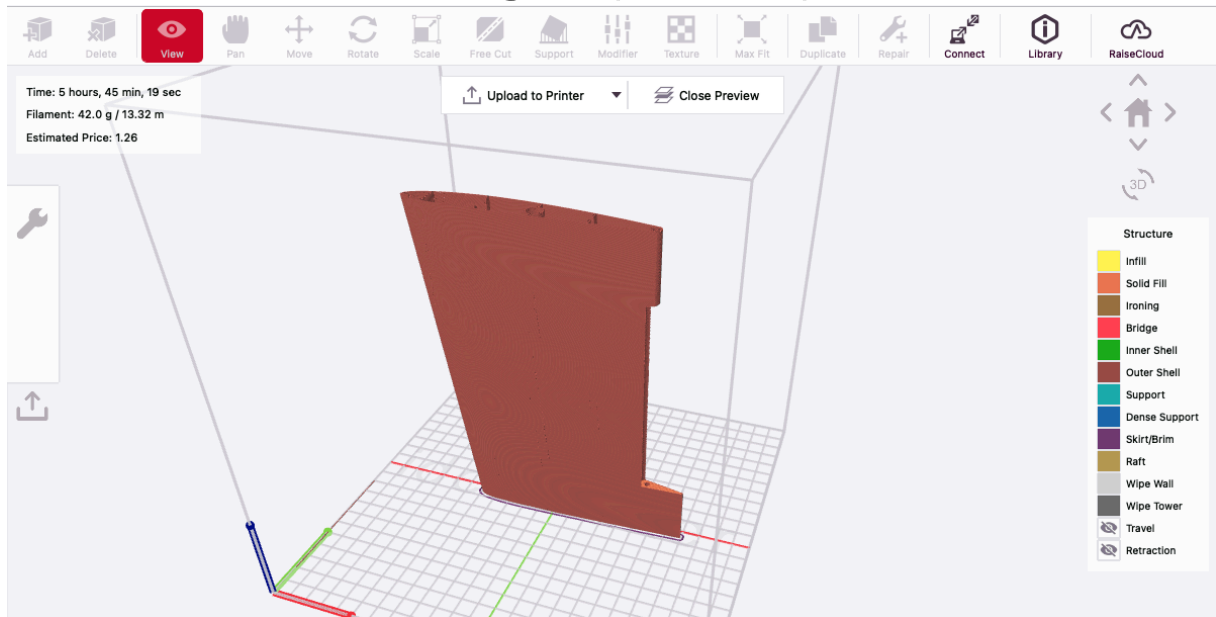



# M1

print parts

## Wing 3R (LW-PLA)

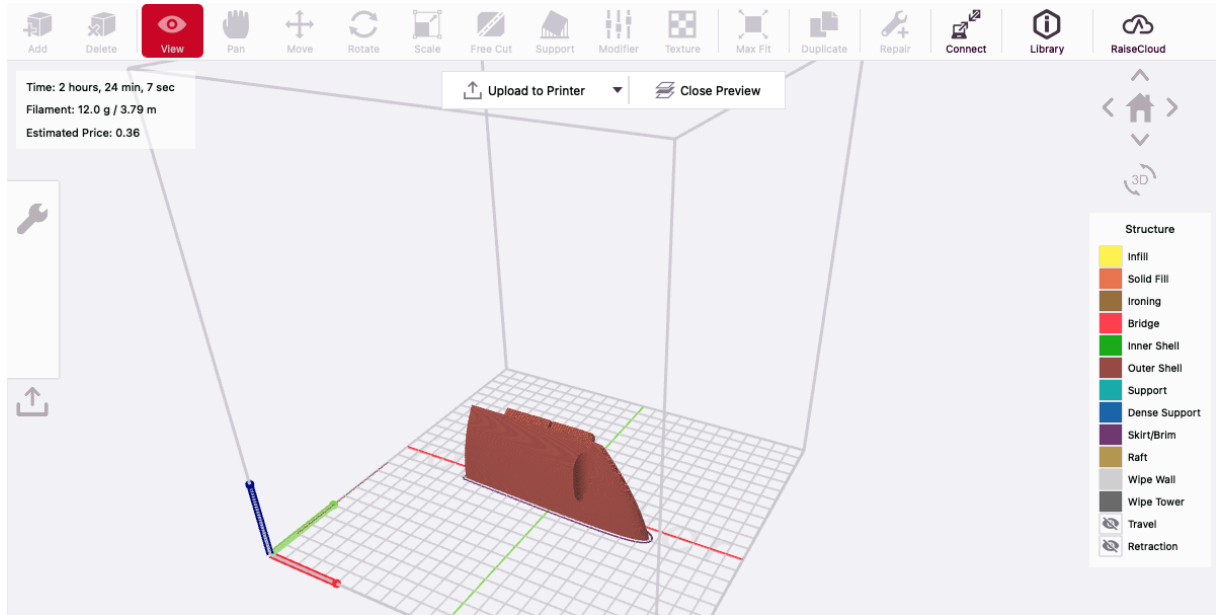

## Wing 4R (LW-PLA)

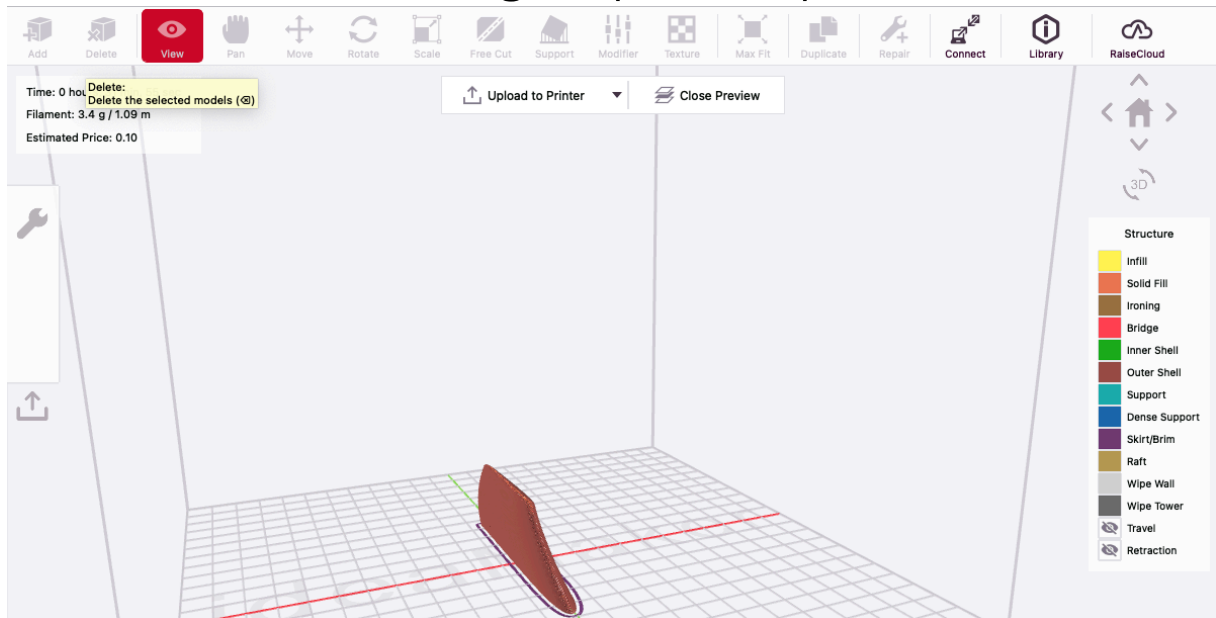



# M1

print parts

## Aileron\_L (LW-PLA)

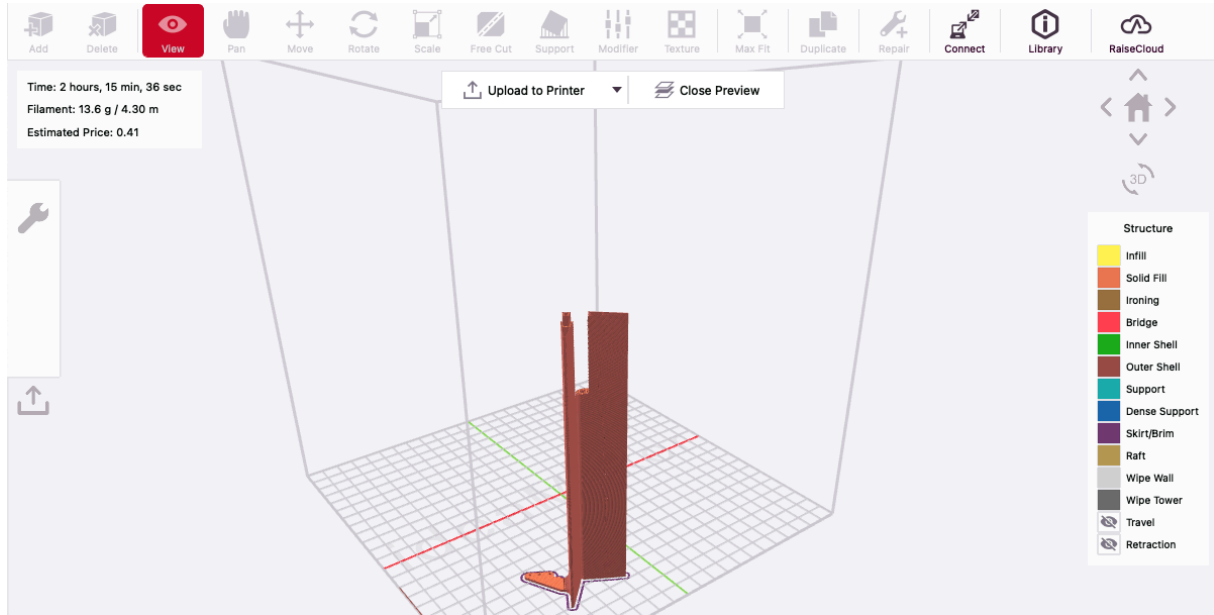

## Aileron\_R (LW-PLA)

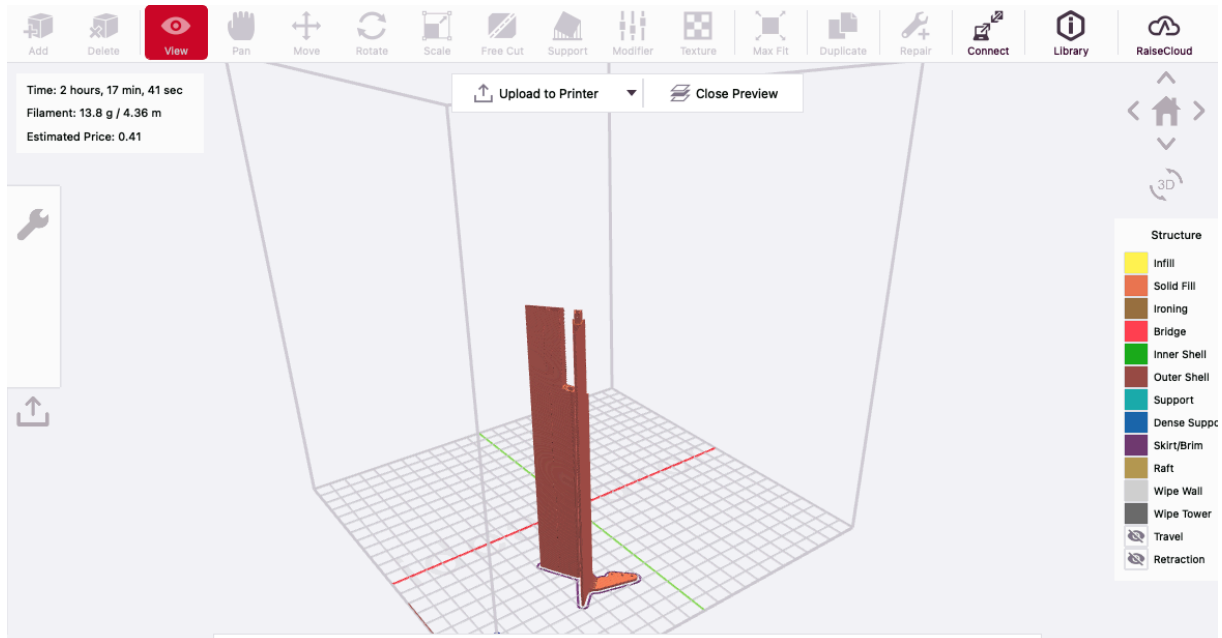



# M1

print parts

## Horizontal Stabilizer L (LW-PLA)

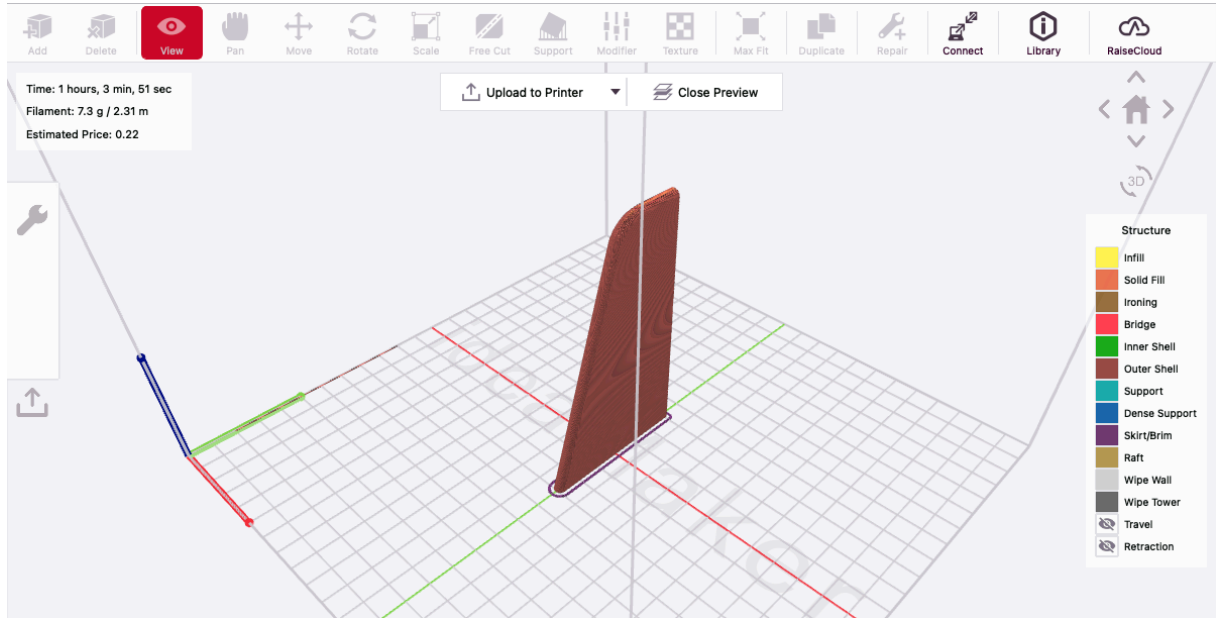

## Horizontal Stabilizer R (LW-PLA)

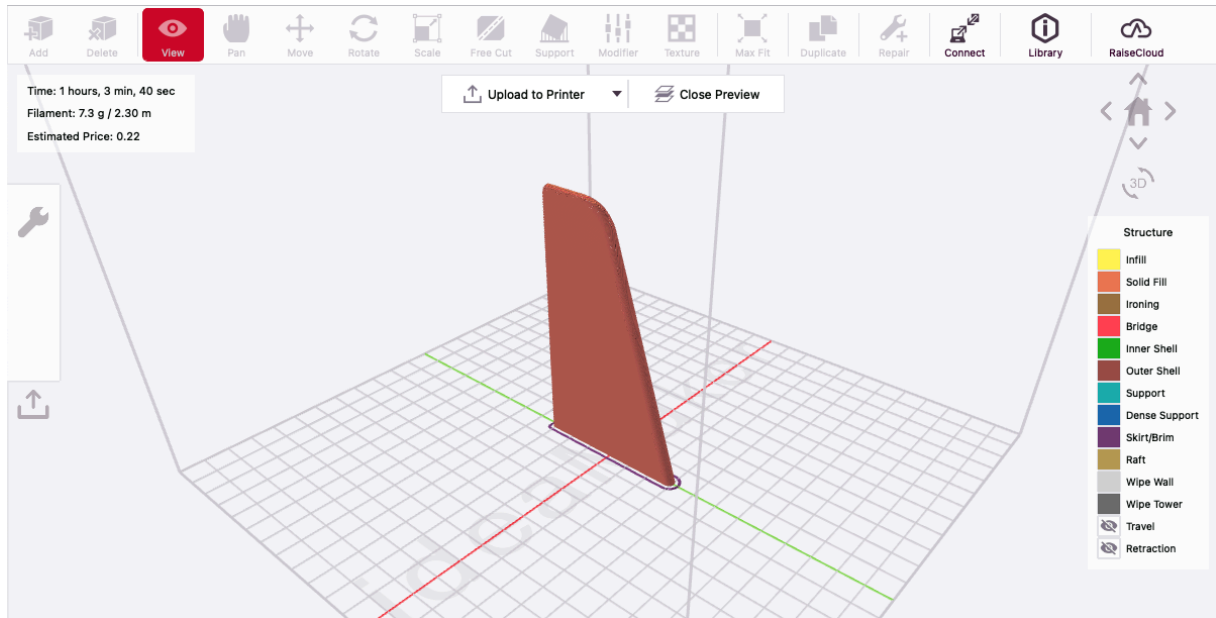



# M1

print parts

## Elevator (LW-PLA)

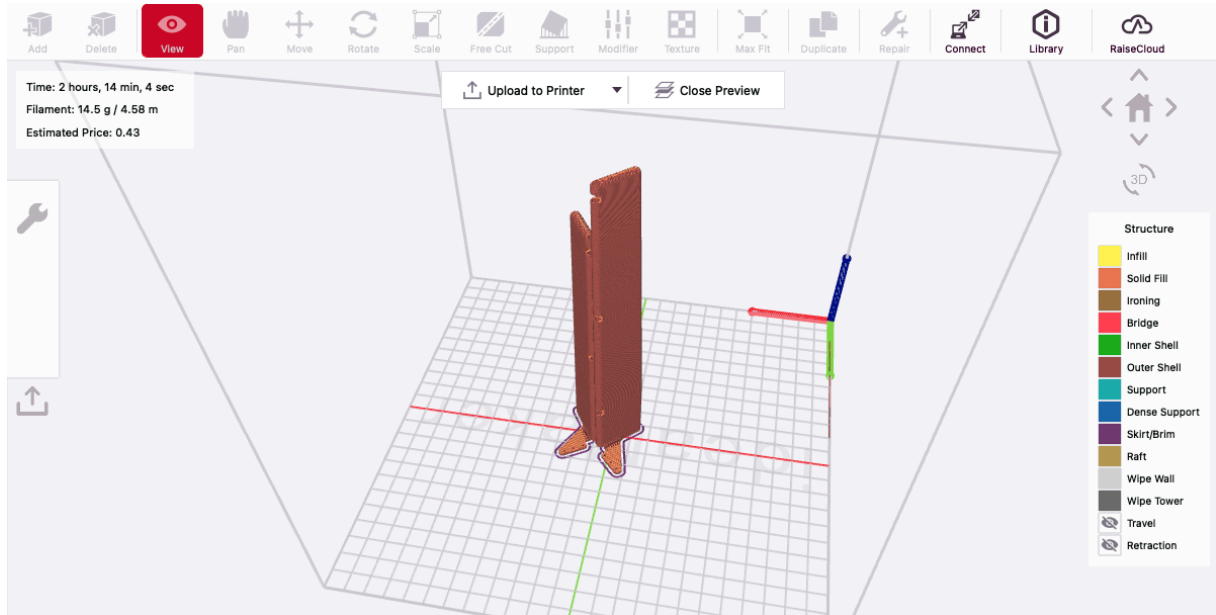

## Vertikal Stabilizer (LW-PLA)

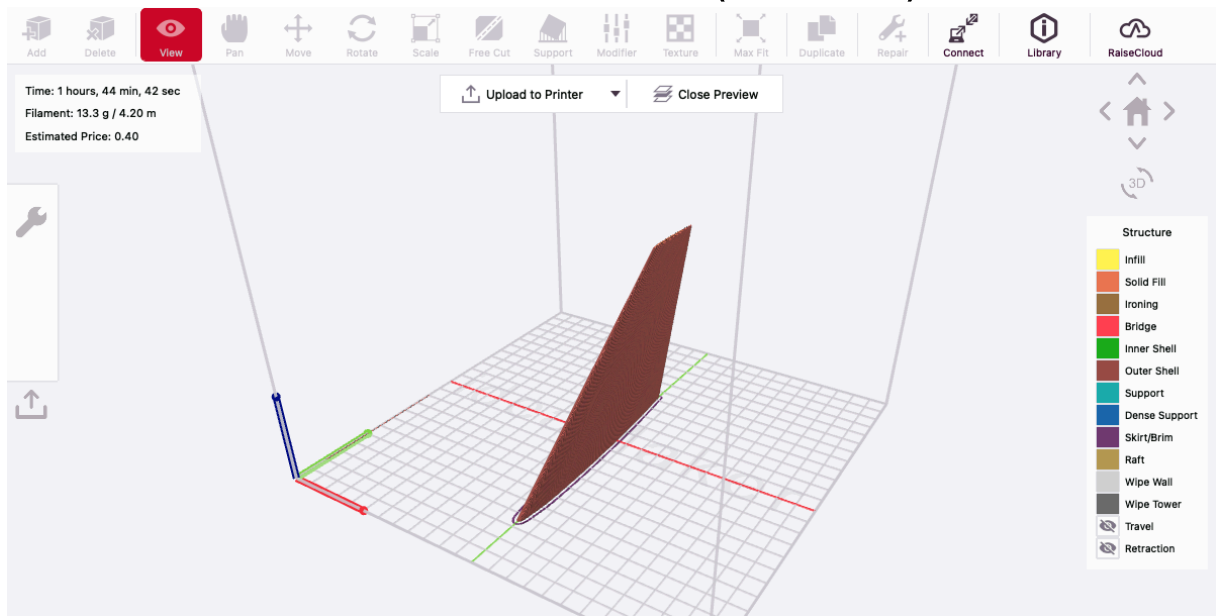



# M1

print parts

## fuselage Servo mount DSM44

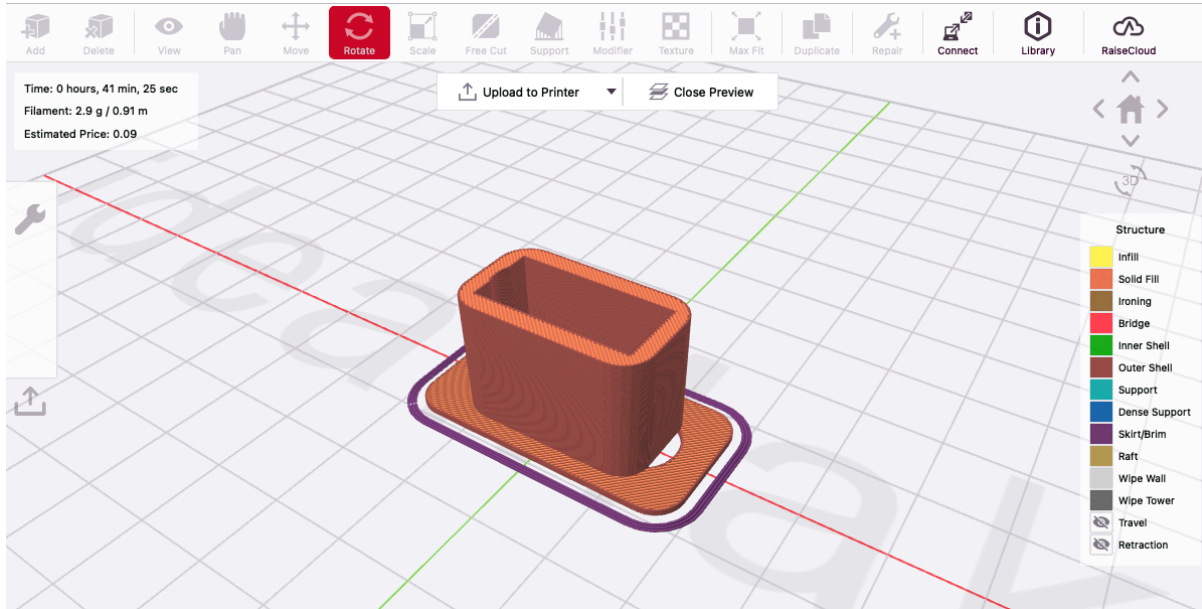

## wing Servo mount DSM44 L+R

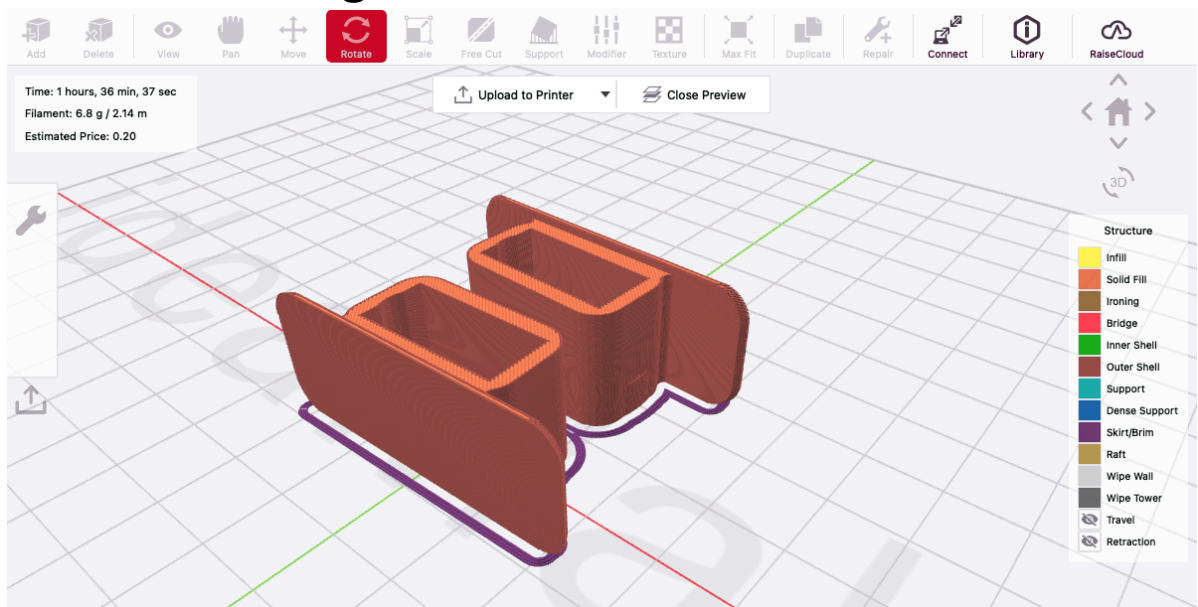



# M1

print parts

Center of gravity

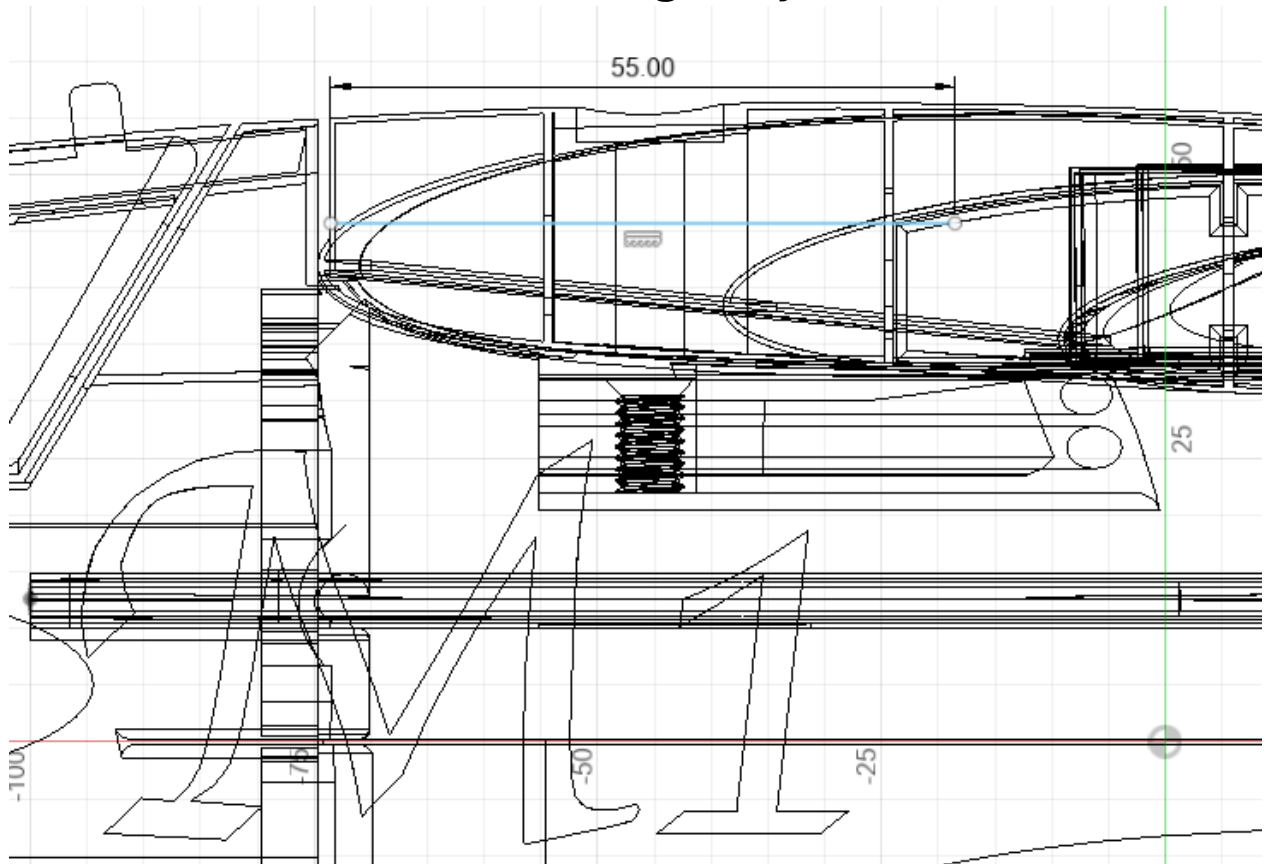



# M1

print parts

blue = LW-PLA

green = PLA

red = carbon

